

**ITEMS:** FFK, FFDK, WFT

# Wave Flag Kit

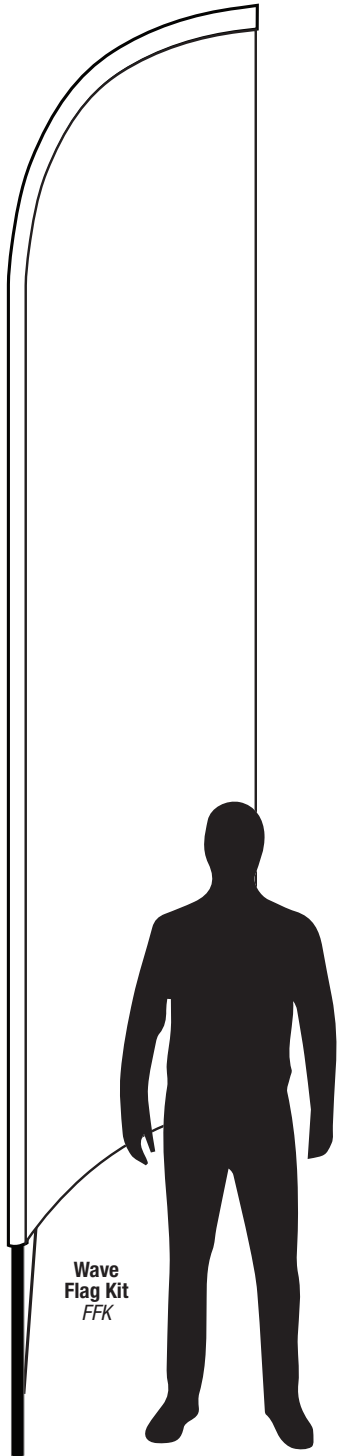

## Wave Flag Kits Include:

- A. 1 Tapered Pole Segment with Clip
- B. 2 Tapered Pole Segments
- C. 1 Flex Pole Segment
- D. 1 10.6' Wave Flag (*Item FF*)
- E. Tire Base Bracket (*Item WFT*)
- F. Tire Base Cylinder
- G. Tire Base Screw

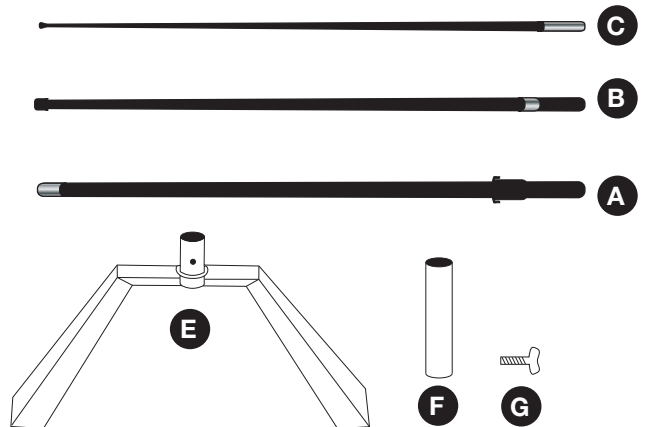

## Tire Base Assembly:

To assemble the tire base, you will first need to remove the tire base screw (G) from the base bracket (E). Next, slide the tire base cylinder (F) into the open hole in the tire base bracket. Use the tire base screw to secure the cylinder to the base bracket. Slide your assembled tire bracket under your desired tire. Make sure to leave room for the flag to move with the wind and not bang against the side of the vehicle.

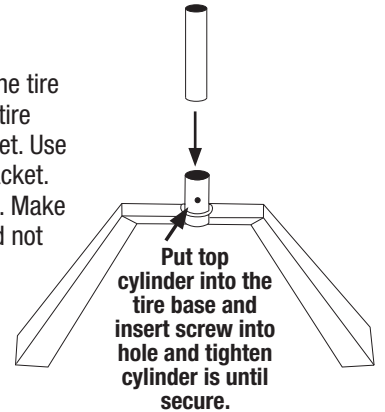

## Flagpole Assembly:



1. To assemble the flagpole, start with the bottom segment, the tapered pole with clip (A), and attach by sliding the wide end of one pole B onto the tapered end of pole A until it is tightened securely and doesn't spin around. Next attach the second tapered pole (B) to the top of connected poles A and B in the same manner.
2. Finish the pole by sliding the flexible pole (C) into the top of the assembled pole. Make sure that the four pole pieces are secured tightly to each other.
3. Starting at the top end of the pole, slide the flag sleeve down the pole and secure the sewn loop at the base of the flag to the clip at the base of pole A.
4. Slide the pole into the open hole in the tire base and you're done!

*Note: If you are having problems with your flagpole spinning around and getting twisted, make sure that the pole segments are secured tightly. The tapered ends will allow the top of the pole to spin around and the flag to get tangled if they are not pushed all the way together.*

### GREAT AMERICAN'S WAVE FLAG KITS:

- ★ Assembles in minutes!
- ★ Durable for Outdoor Use
- ★ Mix and match designs for quantity discounts!

